

Compact digital positioner for pneumatic control valves.

- Positioner can be integrated into valve actuator (no external moving parts for stroke feedback)
- Wide range of strokes 3 - 28 mm
- No steady-state air consumption
- Self-adapting to valve actuator
- Configuration and diagnostic functions by PC-software
- Not sensitive to vibrations
- Protection class IP65
- Available with AS-I control
- No instrumental air required (filtration to 20µm satisfy)
- Also available for the use in Ex-Zone 22
- Available with integrated process controller
- Also for quarter-turn actuators (single acting or double acting)



ATEX-Versions:



ATEX



II 2G Ex ia IIC T4 Gb for Type 8049-ExPro-1

II 1G Ex ia IIC T4 Ga for Type 8049-ExPro-0

Technical Information, standard versions

Version	8049-4	8049-2	8049-ExPro
nominal stroke	3 - 28 mm	3 - 28 mm	3 - 28 mm
voltage of the working resistance	3,5 V (175Ω@20mA)	6,5 V (325Ω@20mA)	8V (400Ω@20mA)
auxiliary energy, pneumatic	max. 6 bar	max. 6 bar	max. 6 bar
air delivery* linear drive	40 NI/min	24 NI/min	24 NI/min
consumption of auxiliary energy in the controlled state	< 0,06 NI/min	< 0,4 NI/min	< 0,4 NI/min
Leakage	< 0,01 NI/min		
ambient temperature	-20 up to +75°C	-10 up to +75°C	-10 up to +75°C
control signal	0/4 - 20 mA opt. 0 - 10 V	4 - 20 mA	4 - 20 mA
auxiliary energy, electric	24 VDC max. 10 W	none	none
adjustment of stroke and zero point	self-learning		
configuration	with PC-Software		
air quality according ISO 8573-1:			
max. particle size and density:	Class 5	Class 3	Class 3
oil content	Class 4	Class 2	Class 2
pressure dew point	Class 3	Class 3	Class 3
	min. 20K (36°F) under ambient temperature		
Actuation gas	compressed air or non flammable gases (nitrogen, CO ₂ ,...)		
mounting to control valve	standardized mounting kits (also with optical position indicator)		
pressure supply port	G 1/8"		
protection class acc. DIN 40050	IP 65 (additional over pressure in the body with scavenging air)		

* at 5 bar pilot pressure

Technical Information, ex-versions

Version	8049-ExPro-1	8049-ExPro-0
General explosion-relevant information		
Applied standards	IEC 60079-0:2011, Ed. 6 IEC 60079-11:2011, Ed. 6	
Type examination certificate (ATEX)	BVS 17 ATEX E088	
Type examination certificate (IEC)	IECEX BVS 17.0080	
ATEX label	II 2G Ex ia IIC T4 Gb	II 2G Ex ia IIC T4 Ga
IEC label	Ex ia IIC T4 Gb	Ex ia IIC T4 Ga
Temperature ranges	Tamb = -10 ... +75°C	Tamb = -10 ... +75°C
Explosion-relevant information for control signal input (Terminals 1 and 2)		
Max. input voltage	Ui = DC 30V	Ui = DC 30V
Max. input current	li = 120 mA	li = 120 mA
Max. input power	Pi = 1000 mW	Pi = 1000 mW
Max. interior capacity	Ci = negligible	Ci = negligible
Max. interior inductivity	Li = negligible	Li = negligible
Explosion-relevant information for alarm output (NAMUR EN 60947-5-6) (Terminals 3 und 4)		
Max. input voltage	Ui = DC 16V	Ui = DC 16V
Max. input current	li = 25 mA	li = 25 mA
Max. input power	Pi = 64 mW	Pi = 64 mW
Max. interior capacity	Ci = 11 nF	Ci = 11 nF
Max. interior inductivity	Li = negligible	Li = negligible
Explosion-relevant information for binary input (Terminals 5 and 6)		
Max. output voltage	Uo = DC 5.4V	Uo = DC 5.74V
Max. output current	Io = 1 mA	Io = 1 mA
Max. output power	Po = 2 mW	Po = 2 mW
Max. external capacity	Co = 65 µF	Co = 65 µF
Max. external inductivity	Lo = 35 H	Lo = 35 H
Explosion-relevant information for PC-COM		
Nominal output voltage	2,8V	2,8V
Max. output voltage	Um = 6.1 V	Um = 6.1 V
Restriction	The interface may only be used for configuration provided that there is no explosive atmosphere.	
Explosion-relevant information for the external path sensor (version with Plug 4)		
Max. output voltage	Uo = 5.0 V	Uo = 5.0 V
Max. output current	Io = 66 mA	Io = 66 mA
Max. output power	Po = 89 mW	Po = 89 mW
Max. external capacity	Co = 94 µF	Co = 94 µF
Max. external inductivity	Lo = 8 mH	Lo = 8 mH

Combination possibilities

	8049-4 (4-wire) version V5	8049-2 (2-wire) version V7	8049-ExPro (ex-version) Version V3	8049-IPC with integrated process controller
standard body	x	x	x	x
ground plate in stainless steel	x	x	x	x
positioner completely in stainless steel	x	x	x	
positioner for part turn actuator single acting	x	x	x	x
positioner for part turn actuator double acting	x			x
positioner for 50 mm stroke	x	x		
feed back module RM-2	x			
feed back module RM-3	x			
feed back module RM-4		x	x	
gauge block	x	x	x	x

Positioner with integrated PID-process controller module

- Compact solution for local controlling tasks
- Suitable for fast controlled systems due to a short cycle time (only 50 ms)
- Internal or external set point value possible
- LED-display easy to read
- Analog inputs and Pt100
- Configurable as P-, PI-, PD- and PID-controller
- Class of protection IP 65



Supply voltage	24 VDC +/-10 %, 350 mA, max. (with positioner)
Sample rate	50 ms
Control variable	Pt100 0/4...20 mA
Set point value	over keyboard or 0/4...20 mA, 0/2...10 V
Input filter control variable	OFF: 20 ms, (Pt100: 200 ms) ON: 800 ms
Alarm output	absolute direct/inverse, relative direct/inverse, Band direct/inverse
Capacity alarm output	max. 24 VAC or DC, max. 70 mA
Control mode	P (with working point y_0), PD (with working point y_0), PI, PID
Ambient temperature	-20 up to 75°C
Protection class	IP65

Connection example Pt-100

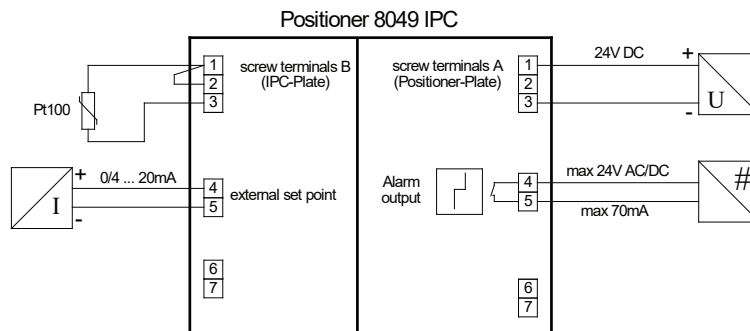

Connection example mA-sensor

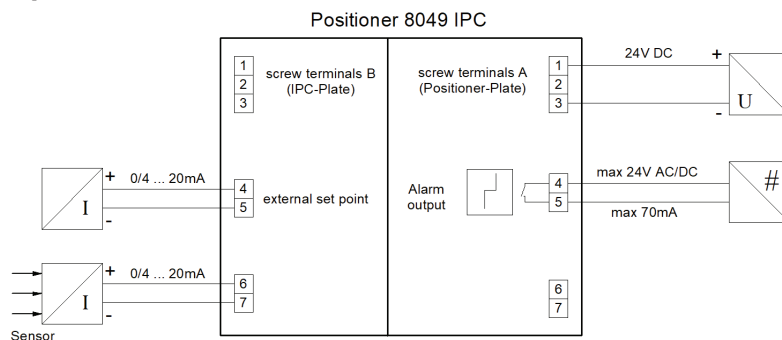

Accessories

Analogue feedback modules

- Feedback on current valve position
- Feedback signal does not require calibration
- Easy to retrofit

Analogue feedback module RM-2

- Feedback for 4 wire design
- 2 electrically isolated limit signal transmitters
- Limit signal transmitters freely adjustable (0-100%) with potentiometer
- Binary input 24V

Technical Information

Supply voltage	24V DC ($\pm 10\%$)
Output signal	4 - 20 mA
Max. adm. working resistance	< 700 Ohm
Temperature range	-20 ... +75°C
Limit signal transmitters	2 pieces
Switching range	adjustable 0-100%
Switching capacity of the limit sign.trans.	24V AC/DC , 70mA
Switching hysteresis	ca. 2,5%

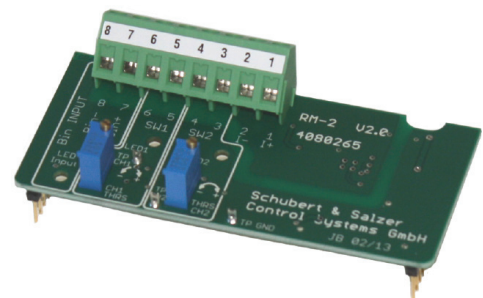

Feedback module RM-3

- Feedback for 4 wire design
- 2 limit signal transmitters according NAMUR (EN60947-5-6)
- Limit signal transmitters freely adjustable (0-100%) with software „DeviceConfig“

Technical Information

Output signal	4 - 20 mA
Internal load	< 7,6V (380 Ω)
Temperature range	-20 ... +75°C
Limit signal transmitters	2 pieces (NAMUR)
Switching range	adjustable 0-100%
Switching hysteresis	ca. 2,5%

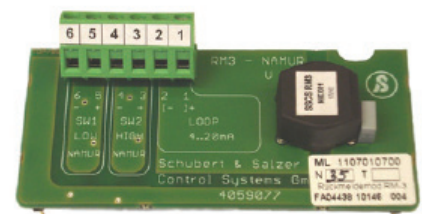

Feedback module RM-4

- Feedback for 2 wire design
- 2 limit signal transmitters according NAMUR (EN60947-5-6)
- Limit signal transmitters freely adjustable (0-100%) with software „DeviceConfig“

Technical Information

Output signal	4 - 20 mA
Internal load	< 8V (400 Ω)
Temperature range	-20 ... +75°C
Limit signal transmitters	2 pieces (NAMUR)
Switching range	adjustable 0-100%
Switching hysteresis	ca. 2,5%

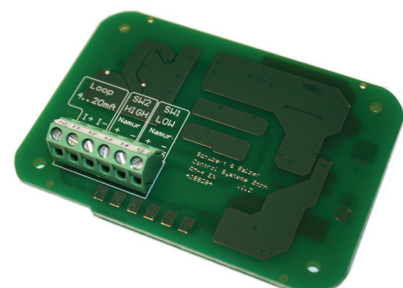

Gauge block

- Gauge block between positioner and connection block
- Reading range of 0-6 bar
- Pressure reading in bar and PSI
- Easy to retrofit



optical position indication for quarter-turn actuators



Materials

	standard version	version „ground plate in stainless steel“	version „completely stainless steel“
positioner housing	Vestamid (electroconductive)	Vestamid (electroconductive)	stainless steel
ground plate	Aluminium, KTL-coated	stainless steel	stainless steel

Housing Versions

Standard version



Completely stainless steel



Ground plate in stainless steel



Ordering number system

										quote only if required		
8049/	-							-		-	S	-
Basic design												
dig. positioner 8049-4 (version 5)		4P5										
dig. positioner 8049-2		2P7										
dig. positioner 8049-ExPro-1		EP3										
dig. positioner 8049-ExPro-0		0P3										
For actuator												
single acting												1
double acting												2
Air delivery												
low												L
standard												S
high												H
Body												
aluminium / plastic												0
stainless steel ground plate												1
body in stainless steel												2
Electro-pneumatic connection												
cable bushing 2 x M16x1,5												0
NPT-thread 1/2"												1
plug connection M12x1, 5-pin												2
Pneumatic connection												
G 1/8"												0
NPT 1/8"												1
Position measuring												
linear potentiometer without sensing pin												0
linear potentiometer with standard sensing pin (L=99,6mm)												1
linear potentiometer with curtaed sensing pin (L=94,4 mm)												G
rotary potentiometer for semi-rotary drive												2
EMV-galvanic separating module for exterior path sensor												3
Optical indicator												
without indicator												0
indicator disc for sensing pin in PA												1
indicator disc for sensing pin in metal												2
rotation angle indicator												3
Auxiliary module												
without auxiliary module												0
intelligent feedback modul RM2 with two limiting value encoders												2
intelligent feedback modul RM3 with two limiting value encoders according NAMUR												3
intelligent feedback modul RM4 with two limiting value encoders according NAMUR												4
IPC-process controller												C
ASI												A
Accessories												
without accessories												0
manometer bloc single acting, scaling in bar and PSI												1
optical position indicator for rotating actuators												2
Further details												
special design (quote only if required)												S
positioner montage (only for the manufacturer)												M
Settings												
standard												-
settings on customer request												1
Special design												
without												-
separated version incl. exterior path sensor for lift drive												1
special design for ex zone 22 (dust)												2

Dimensions

For linear actuators

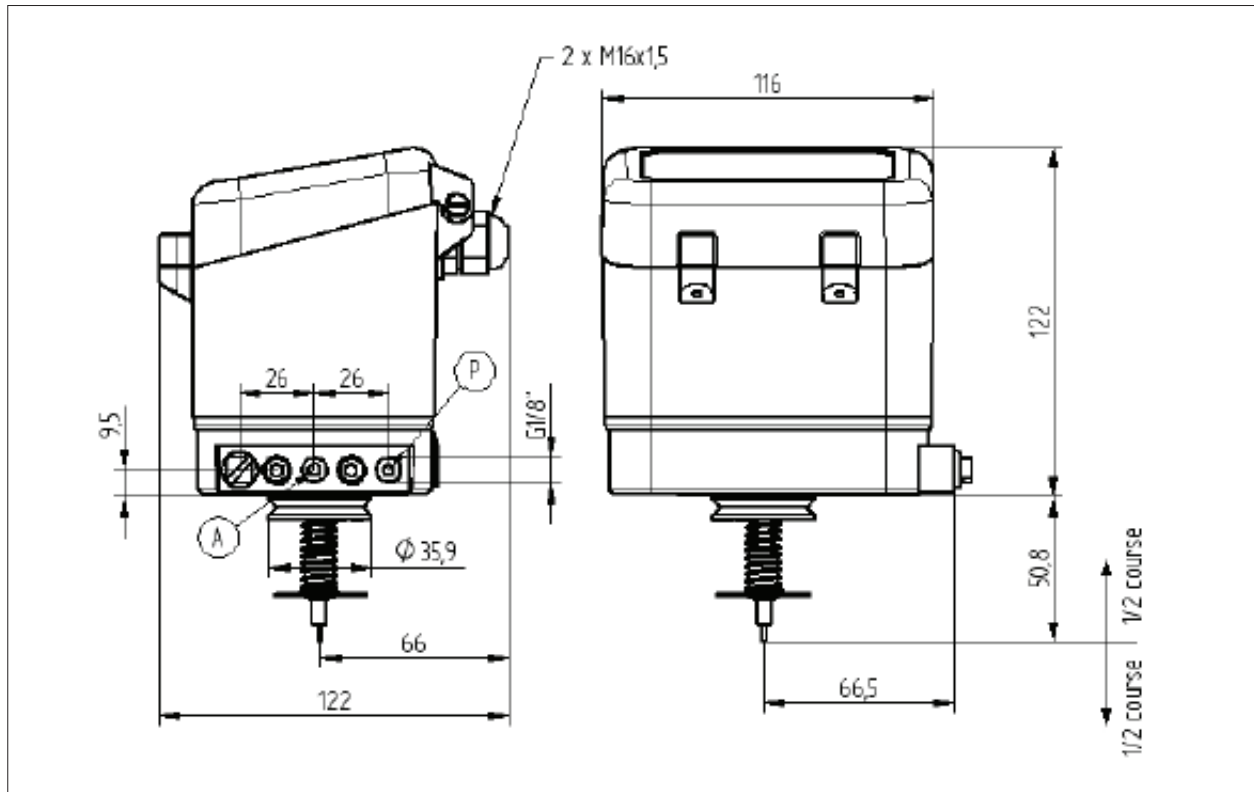

For quarter-turn actuators

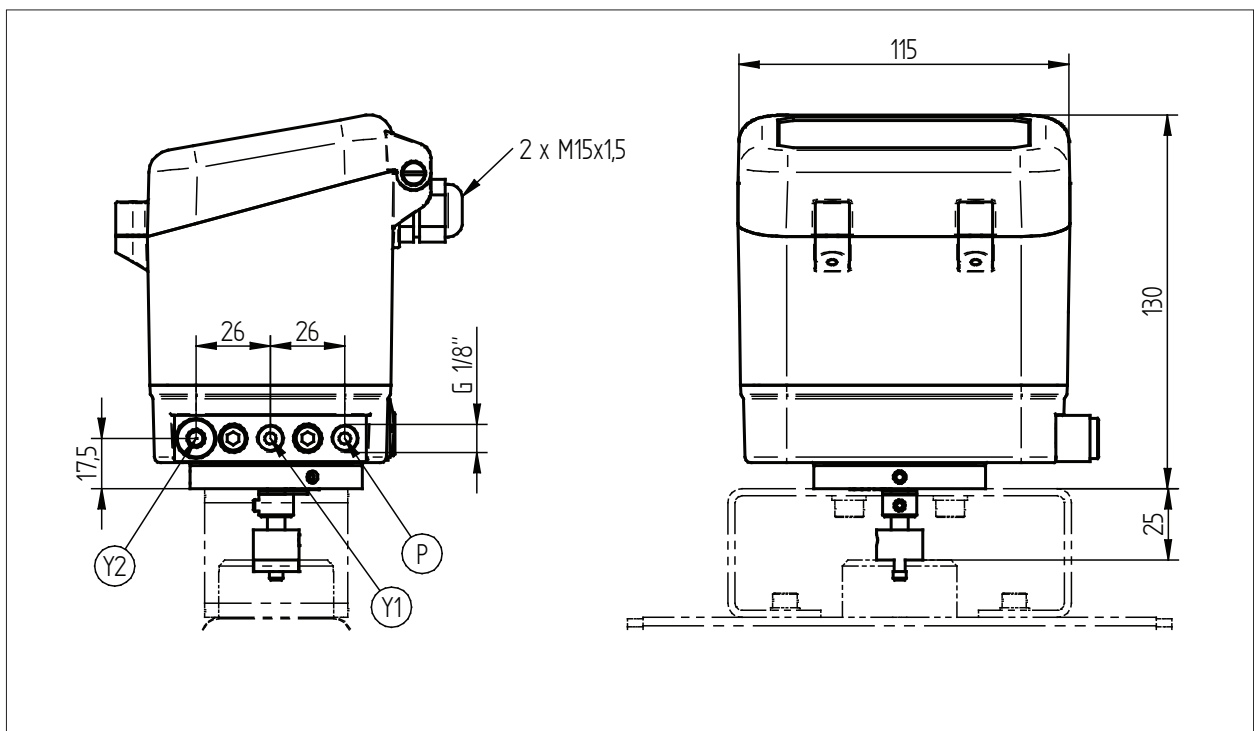

Configuration-Software „DeviceConfig“

Setup-Parameters

Adjustment of controlling parameters (input signal, stroke limitation, tight closing function, control hysteresis, valve function,...)

Live-Monitor

The operating conditions of the positioner, can be viewed with the live monitor.

Configuration-Software „DeviceConfig“

Diagnostic data

Informations of valve stroke, running time, soft- and hardware-versions, achieved temperature- and stroke levels, error messages, number of cycles, operating hours...

Diagnosis																																						
Base	Version information	Temperature- /way classes	Status / Error	Maintenance	Diagnosis																																	
		Way classes <table border="1"> <thead> <tr> <th>Class</th> <th>Range</th> <th>No. hours</th> </tr> </thead> <tbody> <tr><td>W1:</td><td>0 ./ 10%</td><td>232</td></tr> <tr><td>W2:</td><td>11 ./ 20%</td><td>17</td></tr> <tr><td>W3:</td><td>21 ./ 30%</td><td>15</td></tr> <tr><td>W4:</td><td>31 ./ 40%</td><td>7</td></tr> <tr><td>W5:</td><td>41 ./ 50%</td><td>7</td></tr> <tr><td>W6:</td><td>51 ./ 60%</td><td>8</td></tr> <tr><td>W7:</td><td>61 ./ 70%</td><td>16</td></tr> <tr><td>W8:</td><td>71 ./ 80%</td><td>9</td></tr> <tr><td>W9:</td><td>81 ./ 90%</td><td>13</td></tr> <tr><td>W10:</td><td>91 ./ 100%</td><td>57</td></tr> </tbody> </table>	Class	Range	No. hours	W1:	0 ./ 10%	232	W2:	11 ./ 20%	17	W3:	21 ./ 30%	15	W4:	31 ./ 40%	7	W5:	41 ./ 50%	7	W6:	51 ./ 60%	8	W7:	61 ./ 70%	16	W8:	71 ./ 80%	9	W9:	81 ./ 90%	13	W10:	91 ./ 100%	57			
Class	Range	No. hours																																				
W1:	0 ./ 10%	232																																				
W2:	11 ./ 20%	17																																				
W3:	21 ./ 30%	15																																				
W4:	31 ./ 40%	7																																				
W5:	41 ./ 50%	7																																				
W6:	51 ./ 60%	8																																				
W7:	61 ./ 70%	16																																				
W8:	71 ./ 80%	9																																				
W9:	81 ./ 90%	13																																				
W10:	91 ./ 100%	57																																				
		Temperature classes <table border="1"> <thead> <tr> <th>Class</th> <th>Range</th> <th>No. hours</th> </tr> </thead> <tbody> <tr><td>T1:</td><td>< -30 °C</td><td>0</td></tr> <tr><td>T2:</td><td>-30./-15 °C</td><td>0</td></tr> <tr><td>T3:</td><td>-15./0 °C</td><td>0</td></tr> <tr><td>T4:</td><td>0./15 °C</td><td>0</td></tr> <tr><td>T5:</td><td>15./30 °C</td><td>190</td></tr> <tr><td>T6:</td><td>30./45 °C</td><td>331</td></tr> <tr><td>T7:</td><td>45./60 °C</td><td>1</td></tr> <tr><td>T8:</td><td>60./75 °C</td><td>0</td></tr> <tr><td>T9:</td><td>75./85 °C</td><td>0</td></tr> <tr><td>T10:</td><td>> 85 °C</td><td>0</td></tr> </tbody> </table>	Class	Range	No. hours	T1:	< -30 °C	0	T2:	-30./-15 °C	0	T3:	-15./0 °C	0	T4:	0./15 °C	0	T5:	15./30 °C	190	T6:	30./45 °C	331	T7:	45./60 °C	1	T8:	60./75 °C	0	T9:	75./85 °C	0	T10:	> 85 °C	0			
Class	Range	No. hours																																				
T1:	< -30 °C	0																																				
T2:	-30./-15 °C	0																																				
T3:	-15./0 °C	0																																				
T4:	0./15 °C	0																																				
T5:	15./30 °C	190																																				
T6:	30./45 °C	331																																				
T7:	45./60 °C	1																																				
T8:	60./75 °C	0																																				
T9:	75./85 °C	0																																				
T10:	> 85 °C	0																																				
					Back																																	

application example

Positioner 8049 top mounted on GS-Control Valve Type 8021



Positioner 8049 top mounted on Aseptic Right Angle Control Valve Type 6021 with stainless steel body



Text and pictures are not binding. We reserve the right, to alter the equipment.